

How I converted my 2006 Sonata fog lights to DRL-like operation

I converted the fog lights on my 2006 Sonata to DRL-like operation.

When the car is turned on, the fog lights come on.
When the headlights are turned on, the fog lights turn off.
(When the parking lights are on, the fog lights stay on.)

Note: with this mod, you can NOT turn the fog lights on when the headlights are on- the fog light switch will no longer controls the fog lights. (But the fog lights will be on when you have the parking lights on.)

This mod requires no permanent changes to the Sonata, and is a plug in connection inside the car's fuse box.

However, it requires a modification of the fog light relay, so to return a Sonata to original would require purchasing a new fog light relay from the dealer, which I'm guessing would cost about \$20.

I am posting this information because others were interested, however there are no guarantees or support. If your car explodes or you have a heart attack and die I am not responsible.

The modification to the fog light relay and the rest of the installation could be done by anyone with good car audio installation skills.

The following 3-pages have the details.

1

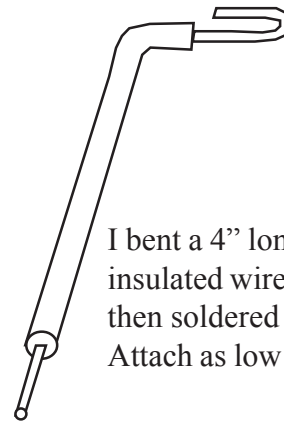
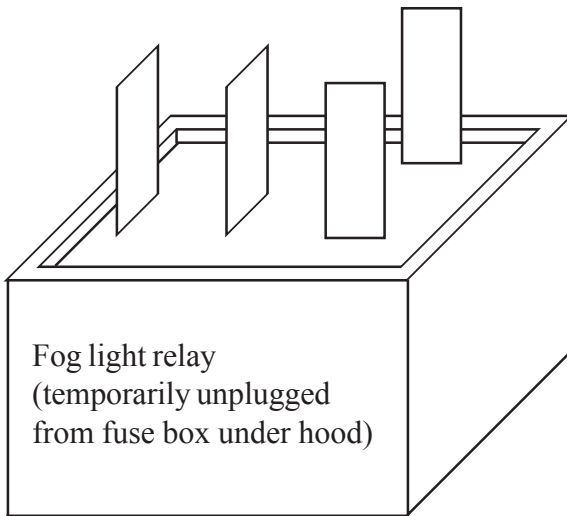

2

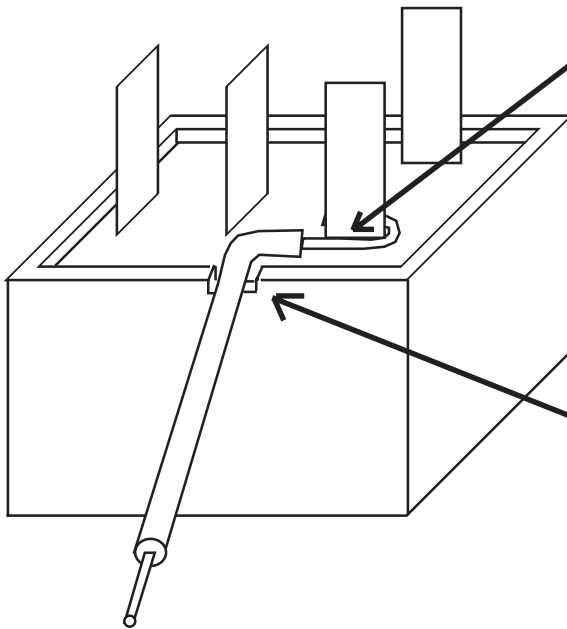

I notched the plastic
edge of the relay here for
clearance

3

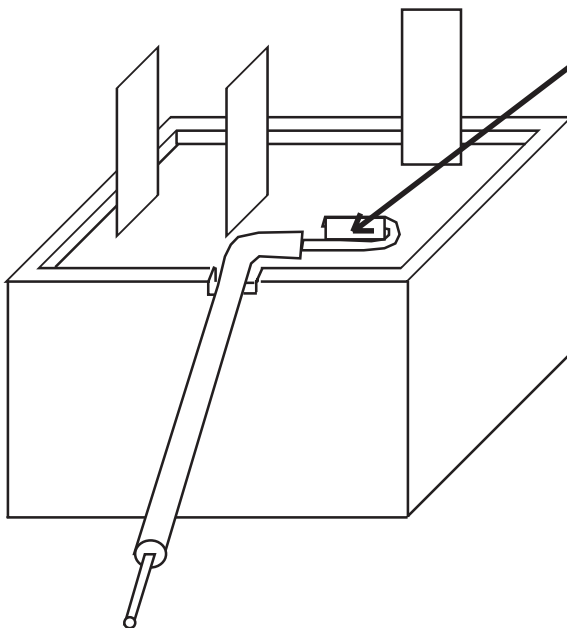

I then covered the rough
edge of the trimmed terminal
with a thin piece of tough
plastic, for example, a piece
of plastic milk carton. (not
shown in this illustration).



Available from Pep boys, etc. Also available from www.PartsExpress.com (part # 071-585)

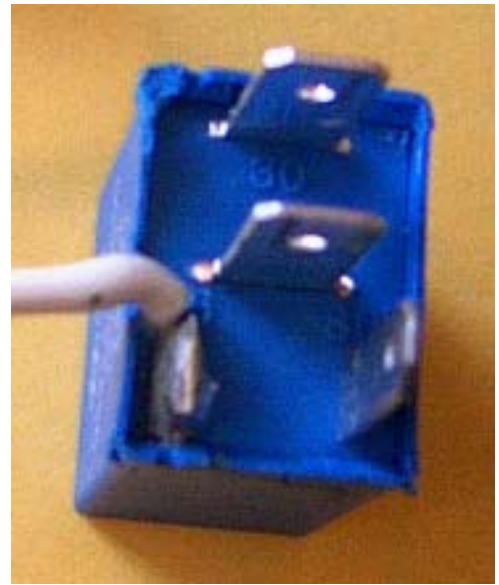

Close up of modified fog light relay. New wire must NOT touch any other relay contacts (other than the one it is soldered to).

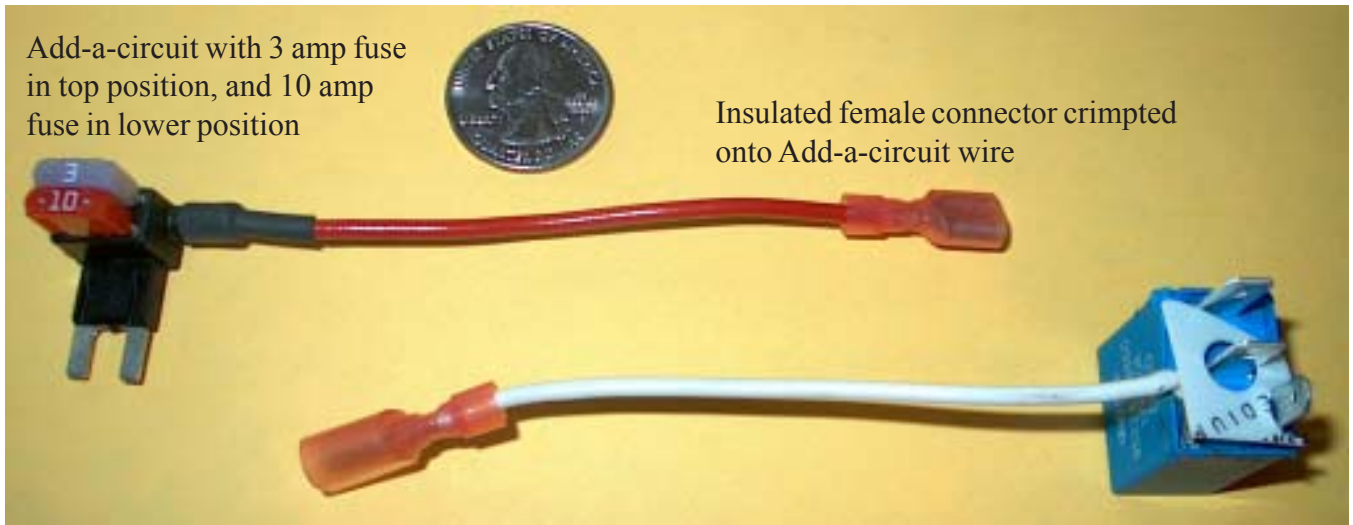

Add-a-circuit with 3 amp fuse in top position, and 10 amp fuse in lower position

Insulated female connector crimped onto Add-a-circuit wire

Insulated male connector crimped onto wire

Modified fog light relay with extra protective insulator made from plastic such as guitar pick or milk carton.

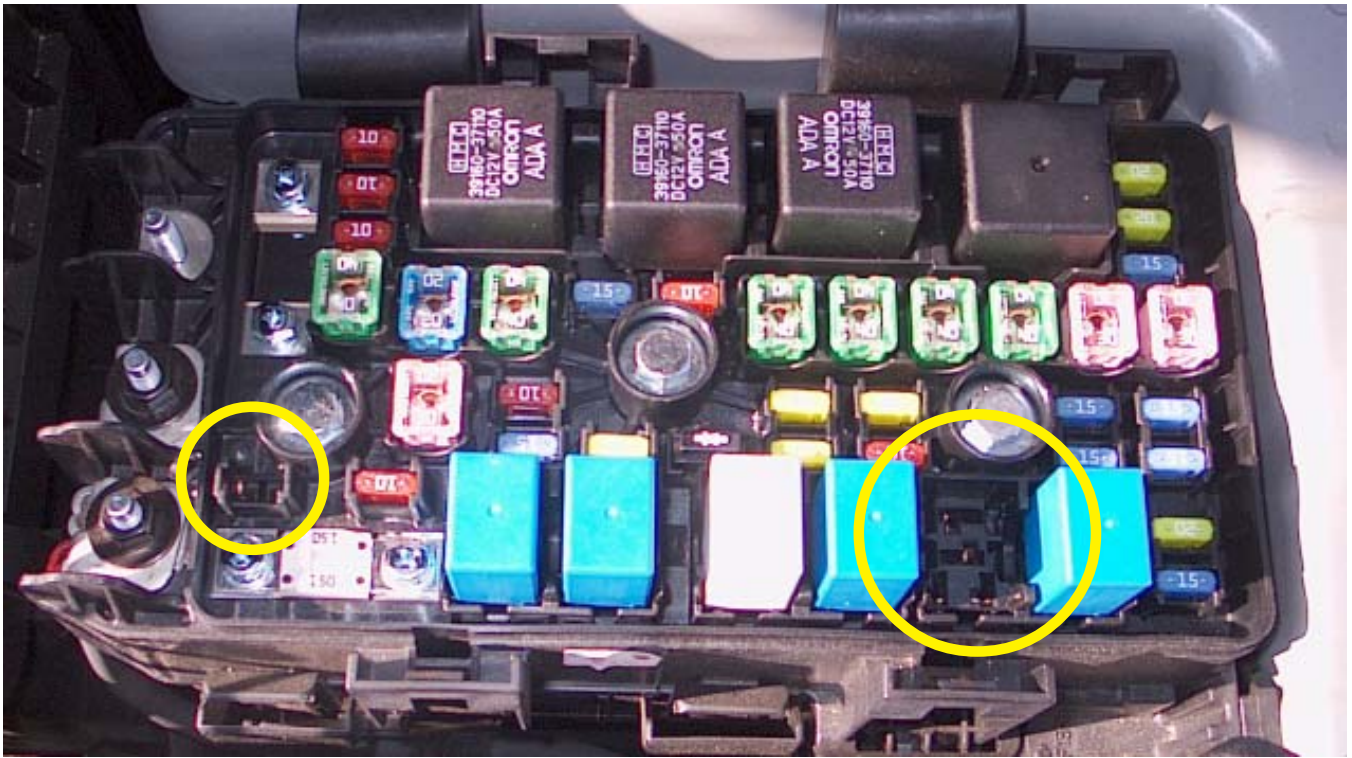

Underhood fuse box with fuse and fog light relay removed

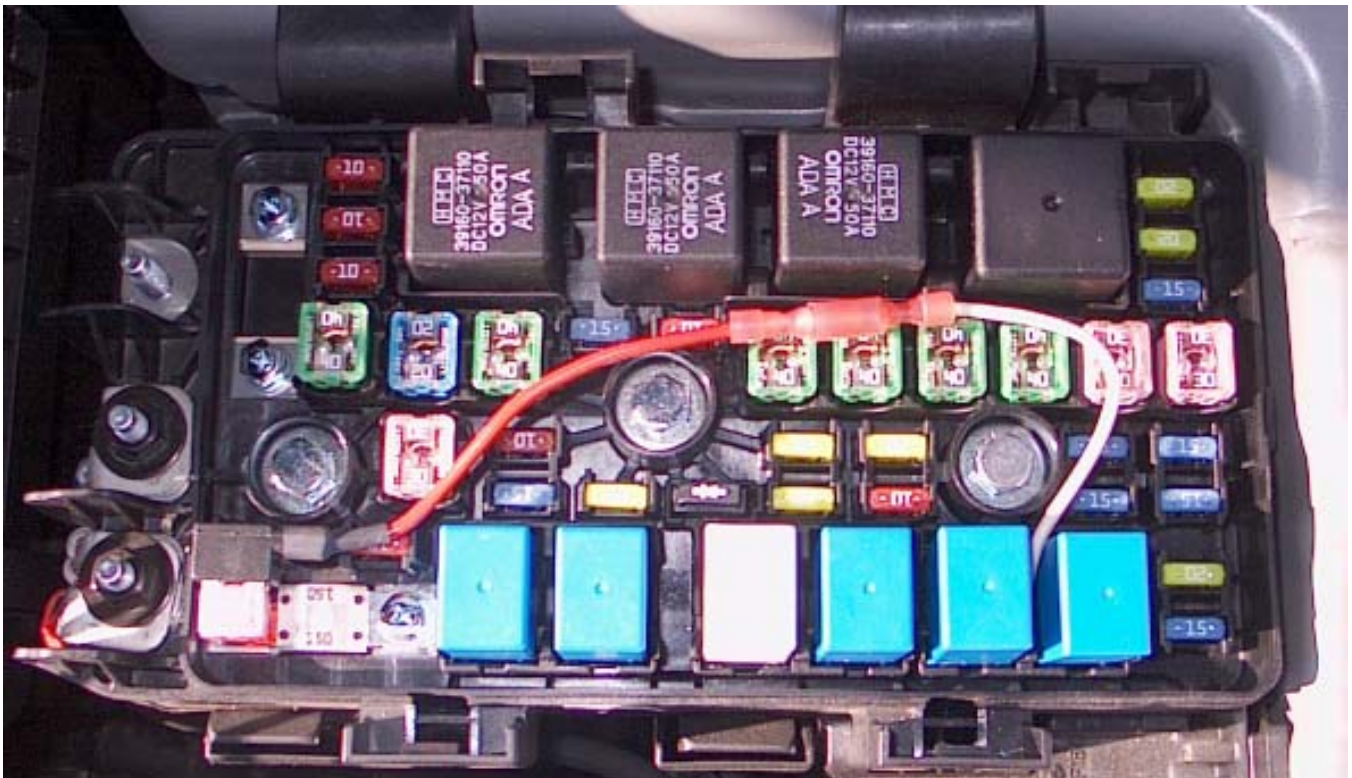

Underhood fuse box with add-a-circuit replacing original fuse, and connected to modified fog light relay